

DESCRIPTION :

The NE1740 is a transistorized PWM servo controller complete with integral power supply. It is primarily intended for use with permanent magnet dc servo-motors rated at up to 1400 watts. The features provided by the NE1740 make it an extremely versatile servo controller that can be configured to operate in a wide variety of applications.



FEATURES :

- Integral power supply allows for operation from either an AC or DC supply.
- Integral bus shunt regulator provides for dissipation of regenerated energy.
- 4-Quadrant operation.
- Link selectable Velocity or Current (Torque) control modes.
- Link selectable Tach or Armature Voltage Feedback.
- External current limit input.
- A voltage input that allows the user to control the peak current limit while operating in speed control mode.
- Current fold-back function limits the average current available to the motor.
- Short-circuit protection.
- Positive and negative over-travel limit inputs.
- LED status indication.

Technical Data			
Supply Voltage (3-phase a.c.)	Max.	105	V AC
	Min.	42	V AC
Bus Voltage	Max	148	V DC
	Min	60	V DC
Armature Output Current	Peak	20	A
	Cont.	10	A
Switching Frequency		18	kHz
Armature Inductance	Min.	1.5	mH
Operating Temperature	Min.	0	°C
	Max.	50	°C
Height		240	mm
Width		55	mm
Depth		220	mm
Protection Class		IP00	

CONTROL SIGNALS :

Command I/P	±10V Differential input
Tach I/P	±60V Single-ended tach feedback input
Enable I/P)
+Limit I/P)--- Active-high, +10V to +28V input
-Limit I/P)
Fault O/P	NPN open collector output. 28V, 75mA max.

USER ADJUSTMENTS :

All adjustments are done using the five multi-turn potentiometers located on the front edge of the board. They are:

- Offset
- Stability
- Peak current limit
- Command gain
- Tach gain



ELECTRICAL CONNECTIONS

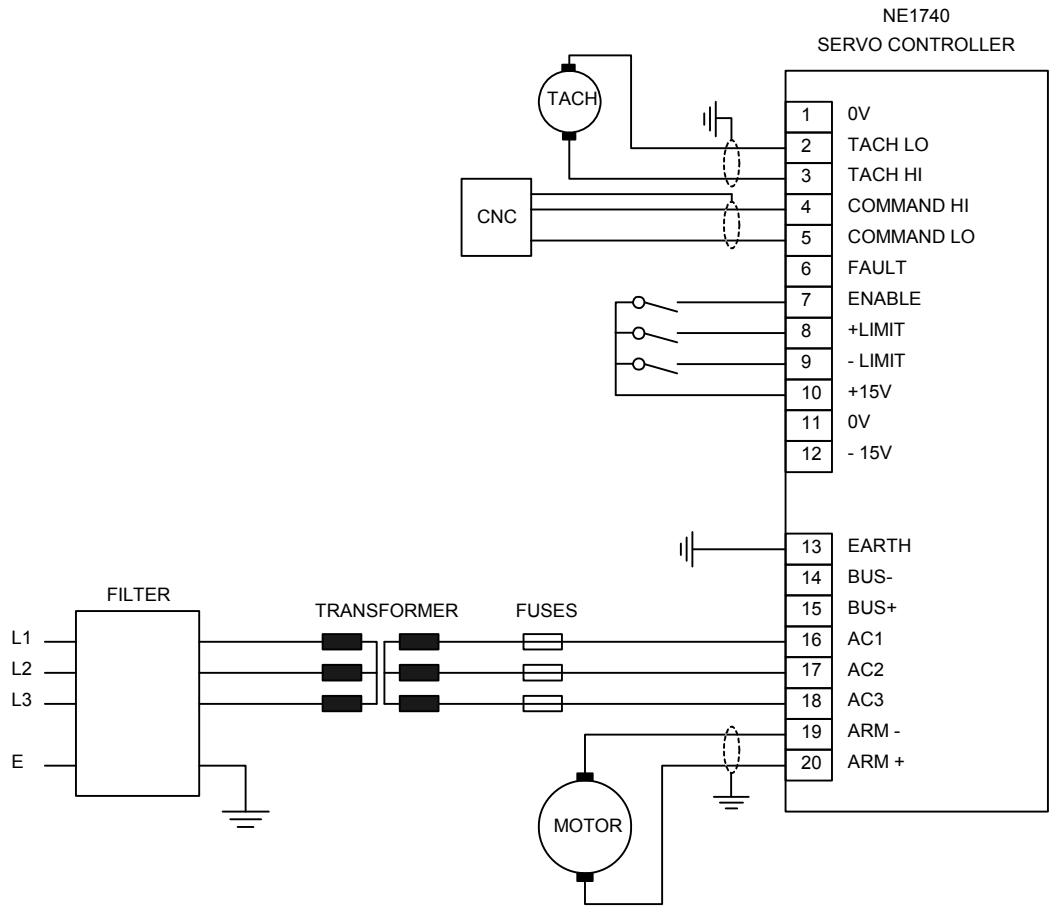

OUTLINE DIMENSIONS

